

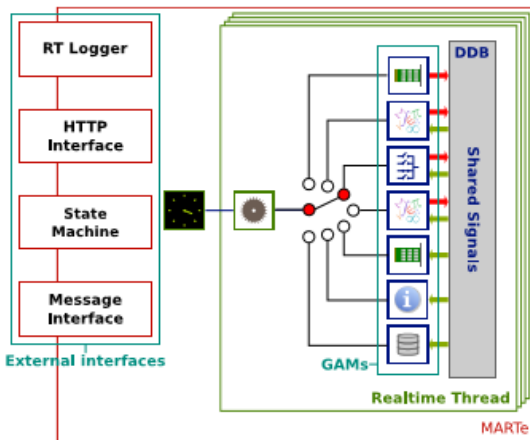

## Faster, safer real-time control systems applications thanks to new QA Framework

*F4E has developed MARTe2, a C++ modular and multi-platform framework for the development of real-time control system applications. This technology could find many applications in the scientific community and industry for control systems of equipment or embedded technologies.*



### The technology

The MARTe2 real-time software is a multi-platform C++ real-time framework which allows the execution of control algorithms, interfaces and services in different operating systems and platforms. This new software architecture is built upon a layered-based library that provides a series of key concepts such as a highly efficient logger mechanism, a built-in object introspection, a garbage collection of named objects and data driven object creation and configuration.

### Higher quality and robustness through the reuse of components

One of the main advantages of the MARTe architecture is the bold separation between the platform specific implementation, the environment details and the real-time algorithms (i.e. the user code). This clear separation of elements has allowed to reuse many components inside the same environment, thus increasing its quality and robustness.

### Fast Quality Assurance of real-time applications

MARTE2 is built upon a layered-based library that make codes safer and easier to debug. The software could find many applications related to control and data acquisition systems (from the scientific community to industrial suppliers). It could also be very useful for the real-time control of embedded technologies (limited amount of memory, number of cores and clock speed).

### Collaboration opportunities

The technology is ready to be used for new real-time applications and is also available for licensing opportunities and further development (for example for fast quality insurance in connected and embedded systems)

Nicolas LOUEE,  
Technology broker  
Phone: +33 6 58 46 71 47  
Email: [nicolas.louee@inextenso-innovation.fr](mailto:nicolas.louee@inextenso-innovation.fr)